

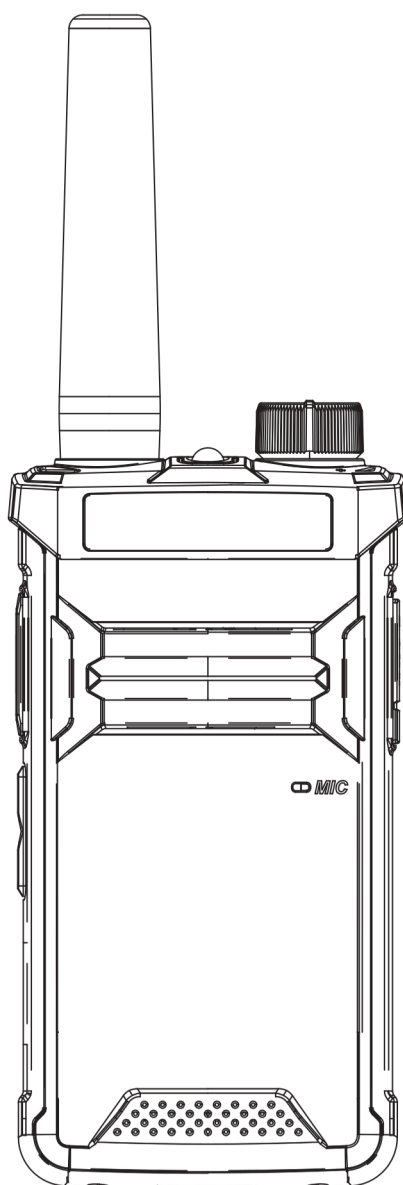

TAURUS

Analog Two Way Radio



TR102

User Manual

Product Overview

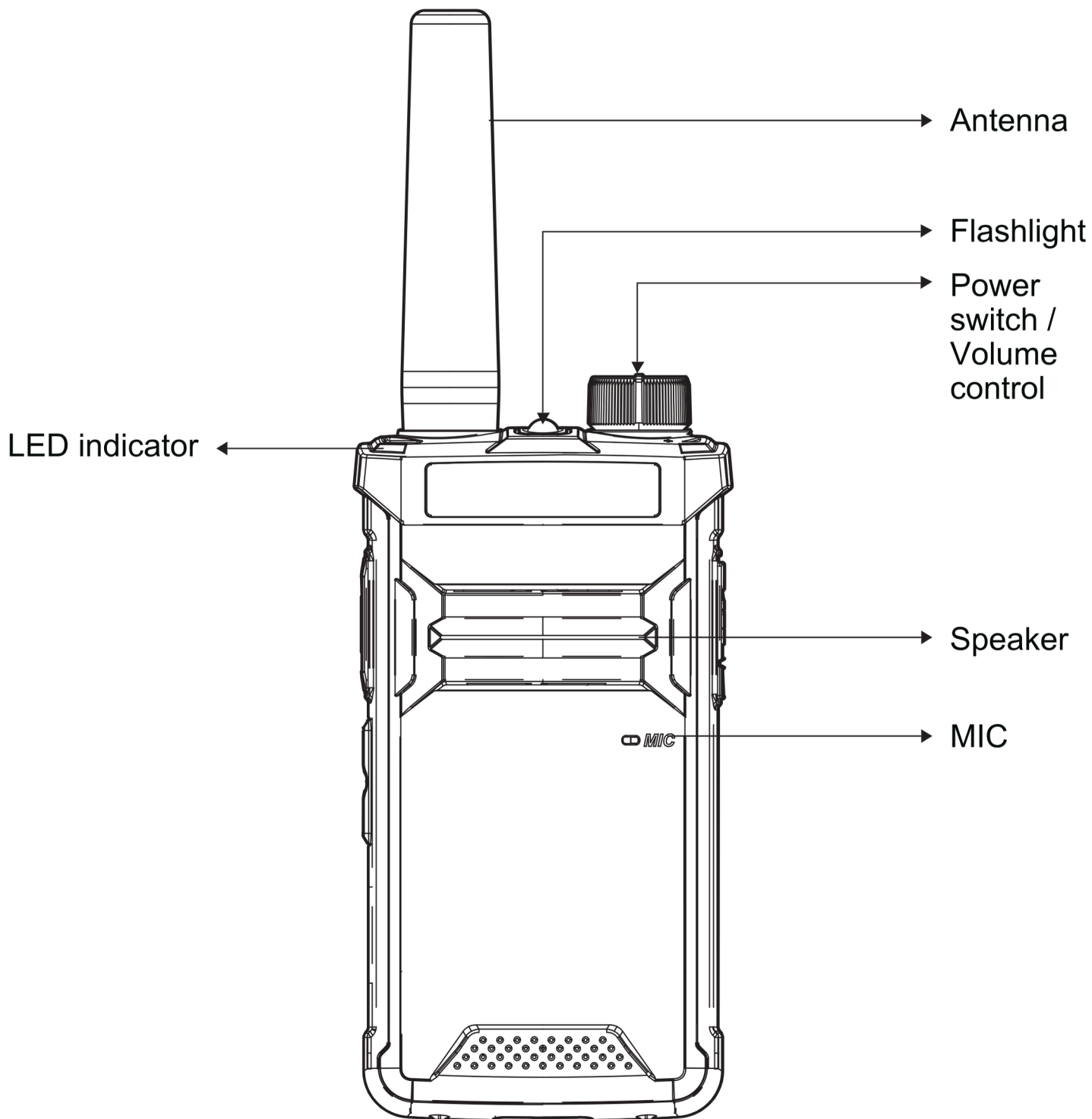

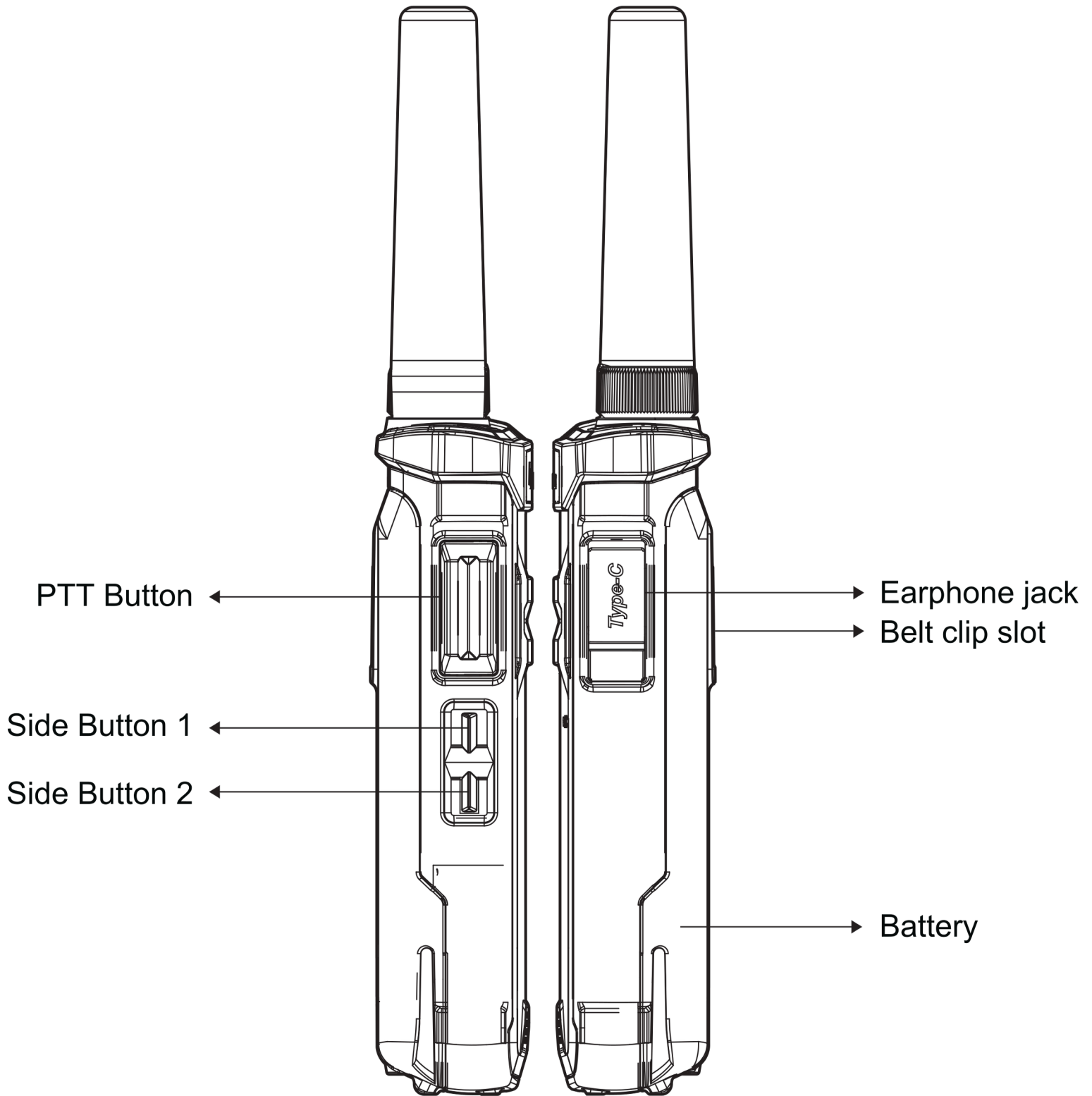

Install/Remove the battery

Align the two notches of the battery with the corresponding rails on the aluminum back cover of the radio, ensuring that the battery is in full contact with the aluminum cover and parallel to it. Slide the battery a long the rails on the back of the radio until it locks into place at the battery lock on the base of the walkie-talkie. To remove the battery, first ensure that the radio is turned off. Press down on the battery lock, confirm that the main unit and the battery are in the released state, and then push the battery backward to remove it from the radio.

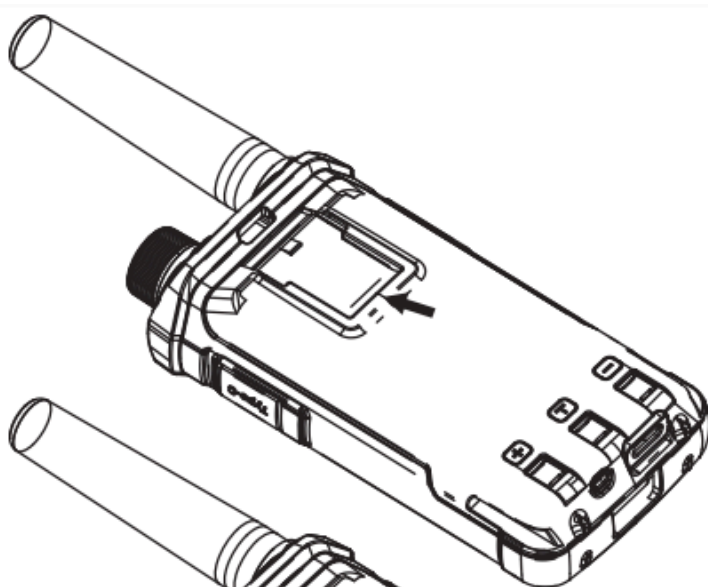

Installation diagram

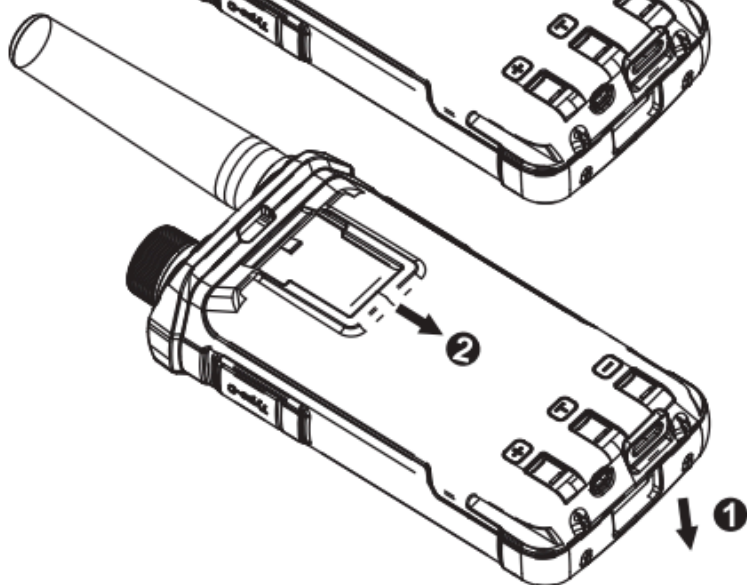

Removal diagram

Attach/Remove Belt Clip

Insert the clip from above the battery and push it down into place.

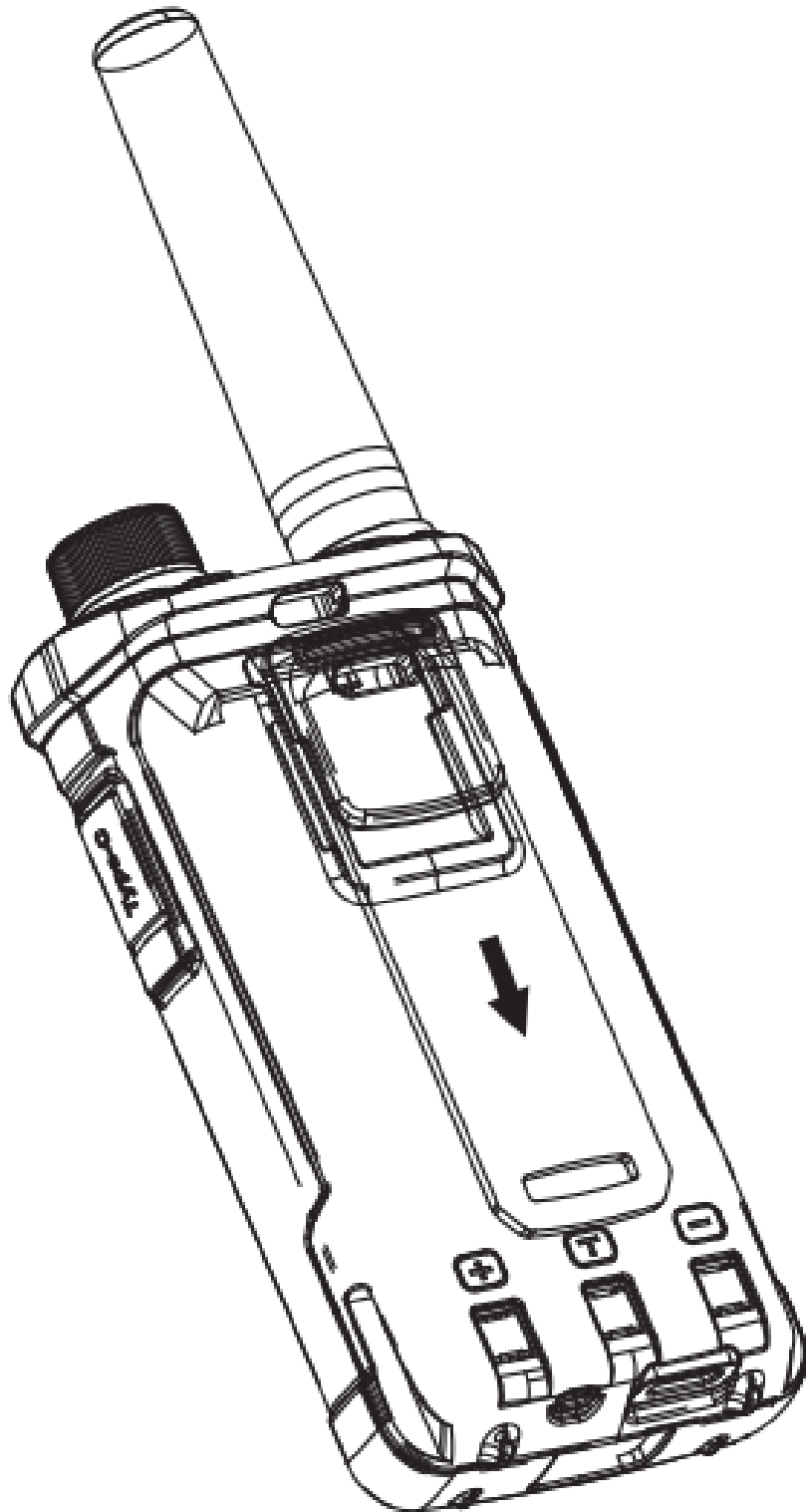

Charging Method and Safety Precautions

After the charger is connected to the power source, insert the battery and ensure it makes proper contact. The charger's indicator light will turn red, indicating that charging has started.

When the battery is fully charged, the charger's indicator light will turn green. If the temperature exceeds the operating range, the battery is damaged, or there is poor contact during the charging process, the charger's indicator light will not illuminate

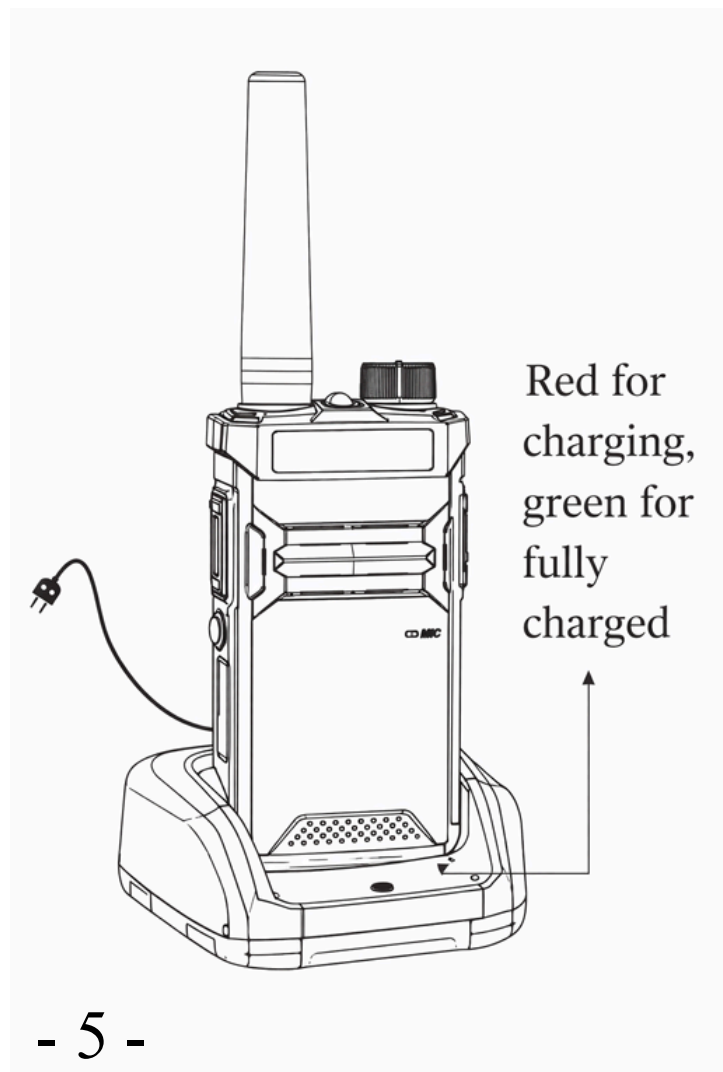
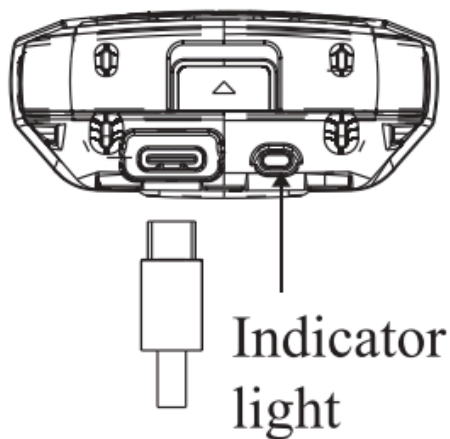

Main function features:

- Global communication, unlimited distance.
- High-fidelity audio
- Low battery voice alert
- Group / Individual/friend calls
- Over-the-air programming (OTA) /Firmware upgrade
- PTT request/priority access Quick group switching
- Ultra-slim design

Unpacking and product inspection

Welcome to use the radio. Before using it, it is recommended that you:

Open the packaging box carefully and confirm whether there are the items listed in the following table in the box. If you find any loss or damage of this product and accessories during transportation, please contact the dealer immediately.

Standard Accessories:

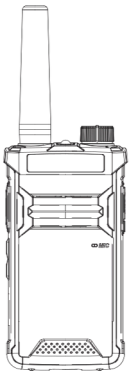

radio

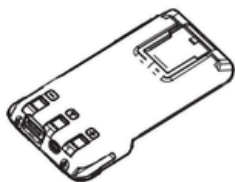

battery

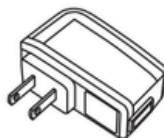

adapter



type-c
cable



belt clip

Channel selection

In the power on state, press the side button 1/ side button 2 to freely switch channels. If you turn on the voice reporting function of this machine, it will broadcast the corresponding channel with voice.

Voice Number-Announcing Function:

This device is equipped with a voice number announcing function, which enables you to quickly know the current channel of the walkie-talkie you are using when operating at night or in the dark. This function can be realized by programming the frequency through computer programming Software.

One-click frequency and code cracking function:

This device has a one click frequency and code cracking function, which matches most analog walkie talkies on the market. It is divided into regular code cracking mode and super code cracking mode. (Please prioritize using the regular code cracking mode, and if unable to crack, please use the super code cracking mode).

Regular code cracking mode:

Step 1: In the programming software, enable the One-click frequency feature. Then, while the device is powered off and on Channel 16, short press and hold Side Button 2, until there are three pleasant prompt tones of 'Didi Di', and accompanied by two indicators of red and green flashing alternately, release the button, indicating that the machine has entered "the first stage of the frequency measurement mode" of the regular code cracking.

Step 2: At this stage, if you need to change the frequency measurement channel, you can switch the channel arbitrarily through the coding switch to enter the "second stage of the frequenc measurement".

Step 3: Enter the "the second stage of the frequency measurement" means that the frequency measurement officially begins, with the target walkie-talkie continues to transmit, to hear the "click" sound and accompanied by the red light flashing twice means that the frequency measurement is completed, automatically store the measured frequency point to the current channel, at this time the machine can talk to the target walkie-talkie. (If you want to detect anti-breaking frequency hopping, please continue to launch the target walkie-talkie after hearing the first 'da' and wait for the second 'da').

Super code cracking mode:

Step 1: While the device is powered off and on Channel 16, long press and hold Side Button 2, until there are three pleasant prompt tones of 'Didi Di', and accompanied by two indicators of red and green flashing alternately, release the button, indicating that the machine has entered "the first stage of the frequency measurement mode" of the super code cracking.

Step 2: At this stage, if you need to change the frequency measurement channel, you can switch the channel arbitrarily through the coding switch to enter the "the second stage of the frequency measurement".

Step 3: Enter the "the second stage of the frequency measurement" means that the frequency measurement officially begins, with the target walkie-talkie continues to transmit, to hear the "click" sound and accompanied by the red light flashing twice means that the frequency measurement is completed, automatically store the measured frequency point to the current channel, at this time the machine can talk to the target walkie-talkie. (If you want to detect anti-cracking frequency hopping, please continue to launch the target walkie-talkie after hearing the first 'da' and wait for the second 'da').

Scrambling and companding function

Each channel can be set with optional functions such as scrambling and companding, and the scrambling function allows you to select the scrambling level.

The scrambling function can achieve voice encryption.

Users without this function will not be able to receive your actual voice, thus keeping your communication confidential. When two - way radios need to have an encrypted conversation, you can select the scrambling option for the optional functions, as long as the scrambling levels are the same.

The companding function can effectively compress part of the set transmission signals before transmitting them to the other end. At the receiving end, the signals are then expanded, thereby maximizing the signal - to - noise ratio of the system, significantly reducing the ambient background noise and improving the sound quality at the receiving end.

Scanning function:

This machine has a scanning function that makes it easy for users to search for calls from users on other channels. The specific operation is: long press the PF2 button, the machine will send out a "beep" and enter the scanning working mode,

the machine will start scanning with the current channel, when receiving a useful signal, the machine will work on the current scanning channel, no signal is received within 5 seconds or the PTT key is not pressed, will continue to start scanning, and the green light will flash when the machine scans, prompting the user that the machine is currently in scanning working mode; If you press and hold the scan key again in the scanning mode, the machine will send out a "beep", indicating that you will exit the scanning mode and enter the channel where the channel switch is located to work.

Alarm function:

This machine has alarm function, local alarm and remote alarm (the alarm signal can be modulated to the high-frequency signal and transmitted, so that the machine using the same frequency and the same sub-audio can receive the alarm signal sent by the machine, so that the receiver knows that the transmitter needs emergency information such as emergency help); The specific operation is: the PF1 button function is set to an emergency alarm, press the PF1 button, the machine will directly enter the alarm mode, continue to send out the alarm sound, if you want to end the alarm, you can directly press the [PTT] button to exit the alarm mode.

Frequency hopping function:

Frequency hopping on/off can be set for each channel. Intercom encryption can be realized, so that other models of machines can not receive your intercom, so that your communication is confidential.

(Note: 1. If the "frequency hopping" column is selected "on", the other party needs to use the same machine to set "on" to intercom) 2. "CTCSSDCS encoding" and "CTCSSICS decoding" are analog subtone digital subtone/none, as long as the "frequency hopping" column selects "on", it means that the frequency hopping function is on) When choosing anti-breaking frequency hopping, be sure to turn off learning frequency hopping, and choose to turn on frequency hopping.

You can also select the frequency hopping mode through the frequency programming.

Frequency programming encryption function:

This device is equipped with frequency programming and encryption functions, which can protect your frequency and sub-audio data from being known by others.

Meanwhile, it can also safeguard the information of you and your clients. The specific settings can be configured through the frequency programming software.

Wireless copying function:

This machine has a wireless copy function, you can copy the frequency of any one to any walkie-talkie in the same series. On the 2nd channel, press and hold PF1 and PTT to power on and enter the wireless copy transmitter mode. On the 2nd channel, press and hold the PF1 button to power on and enter the wireless copy reception mode.

After entering the mode, the transmitter presses the PTT to start the transmission.

Time-Out Timer (TOT) (The function of turning it on/off can be set through computer programming software).

The time of the Time-Out Timer (TOT) can be set through the programming software (it can be set to 15 seconds, 30 seconds, up to 600 seconds; with an increment of 15 seconds for each level). If you keep transmitting until the time set for the Time-Out Timer is reached, the walkie-talkie will stop transmitting and simultaneously emit a long warning sound. To stop the warning sound, release the [PTT] button. Press the [PTT] button again to resume transmission.

VOX, Voice - Operated Exchange function

This device is equipped with a voice control function.

When voice is detected, the walkie-talkie will automatically switch to the transmitting mode. The specific operations are as follows: This function is implemented by programming the frequency through computer programming software.

When the voice control function is checked, it means the voice control is on: when it is not checked, it means the voice control is off. The gain level of VOX and the voice control delay time of VOX need to be adjusted by programming the frequency through computer programming software.

Note: The higher the gain level of VOX is, the lower the volume required for voice control will be (the gain level of VOX can be selected from level 1 to level 9). The larger the voice control delay time of VOX is, the longer the time for voice control to exit will be (the voice control delay time of VOX can be selected from 0.5s, 1s, 1.5s, 2s, 2.5s, 3s).

Standard Technical Specifications

Basic parameters			
Size	113.5X58X23 .5mm		
Antenna	Length51mm diameter14.3mm		
Frequency range	400-470MHz	Microphone Impedance	2.2k Ω
Number of channes	16	Working voltage	3.8V
Channel spacing	25kHz/12.5KHz	Frequency stability	$\pm 2.5 \times 10^{-6}$
Antenna Impedance	50 Ω	The weight of Machine	118.6g
Transmitter			
Carrier Frequency Tolerance	$\pm 2.5 \times 10^{-6}$	Occupied Bandwidth	≤ 16 kHz
Carrier Frequency Tolerance	≤ 2 W	Modulation Characteristics	The deviation from the 6 dB/octave emphasis characteristic shall not be greater than ± 3 dB.
Modulation sensitivity	12 ± 4 mV	Spurious radio frequency components	$\leq 7.5 \mu$ W
Modulation distortion	$\leq 5\%$	Adjacent Channel Power	≤ -65 dB
Modulation Limitation	≤ 5 kHz	Transmitting signal-to-Noise Ratio	≥ 40 dB
Receiver			
Reference Sensitivity	Better than -119dBm	Audio Response	The deviation from the 6 dB/octave de-emphasis characteristic shall not be greater than +2 dB and not less than -10 dB.
Squelch- On Sensitivity	$\leq 0.22 \mu$ V	Co- channel rejection	≥ -8 dB
Audio power	1000mW	Blocking	≥ 85 dB
Audio distortion	$\leq 5\%$	Adjacent Channel Selectivity	≥ 65 dB
Modulation Reception Bandwidth	$\geq \square \pm 7$ kHz \square	Received Signal-to-Noise Ratio	≥ 40 dB



Taurus brand, logo, and designs are the property of Nemer Enterprises S.A.R.L
www.nemerenterprises.com